

500.694-00

602.008-02

MASSA PORTA
80 kg - MAX

FINITURA NERA
OSSIDAZIONE
PROFONDA
50 micron

ALTEZZA
PORTA
min 1000 mm
MAX 3000 mm

INTERVALLO
UTILIZZO
min. -15 °C
MAX +40 °C

LARGHEZZA
PORTA
min 500 mm
MAX 800 mm

* PORTA FINO A 1600 mm
IN BASE ALLA POSIZIONE
DELL'ASSE

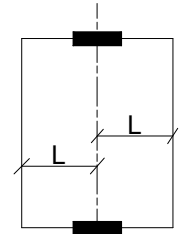

* L MAX= 800mm

PIVOT STRONG INOX 11 - VA E VIENI
CON FERMO A 0° E +/-90°

codice: **500.697-00**

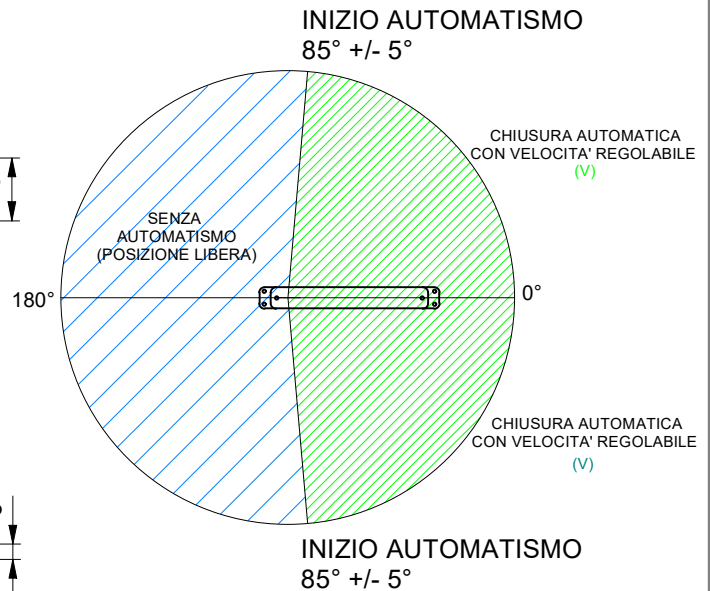
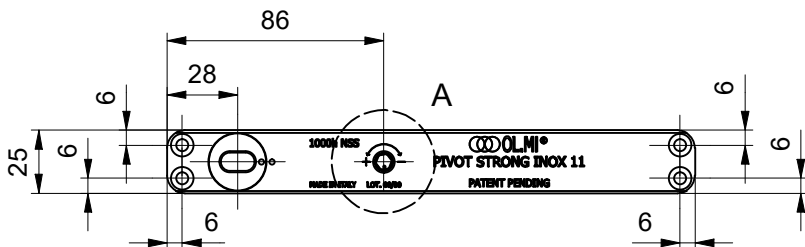
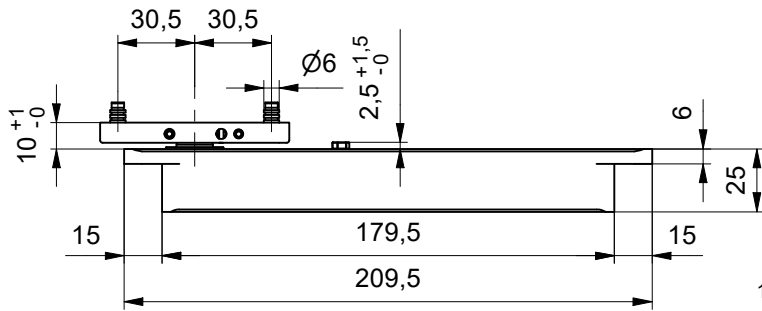
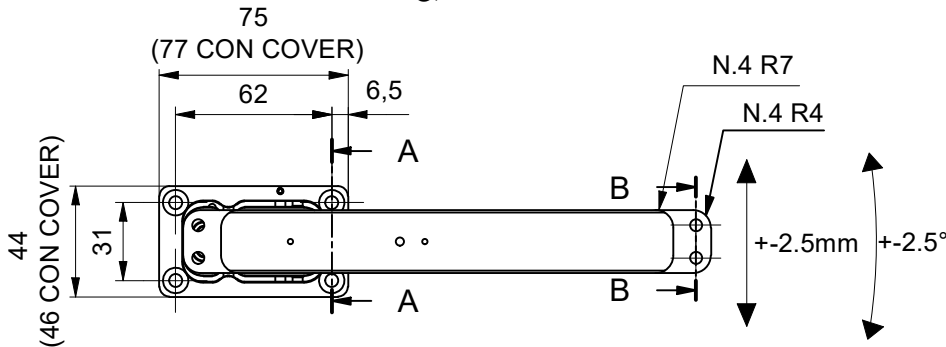
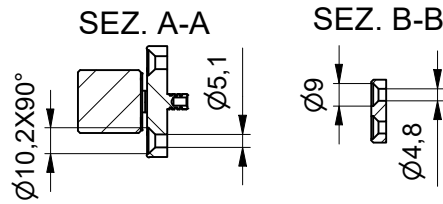
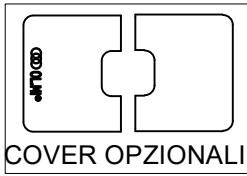

LAVORAZIONE
PORTA

N.8 R7

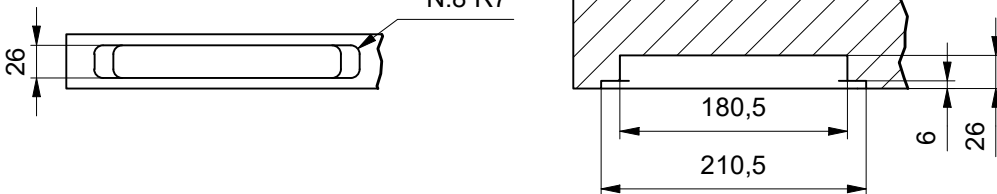

DETTAGLIO A (2 : 3)

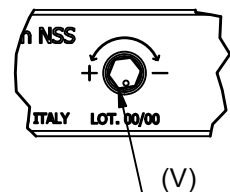

CODICE 602.015-00

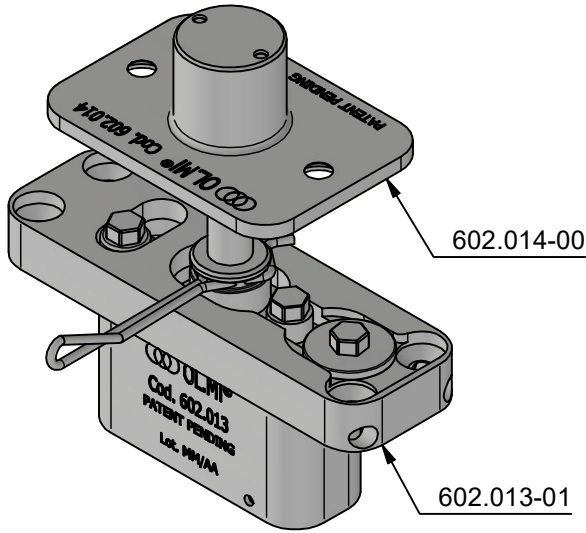

MASSA PORTA
120 kg - MAX

FINITURA NERA
OSSIDAZIONE
PROFONDA
50 micron

ALTEZZA
PORTA
min 1000 mm
MAX 3000 mm

INTERVALLO
UTILIZZO
min. -15 °C
MAX +40 °C

LARGHEZZA
PORTA
min 500 mm
MAX 1000 mm
* PORTA FINO A 2 METRI
IN BASE ALLA POSIZIONE
DELL'ASSE

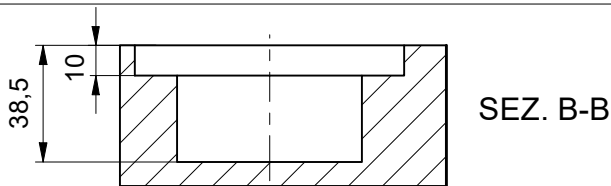
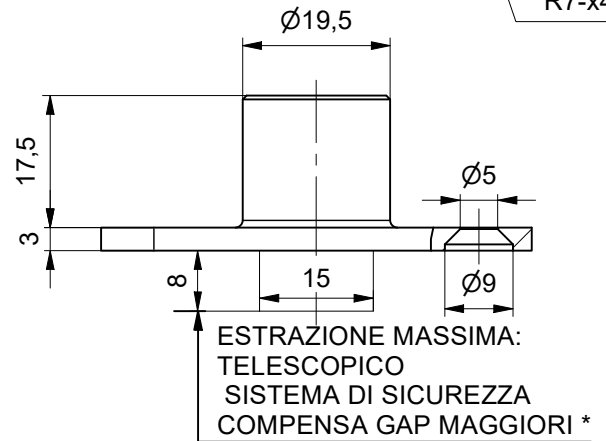
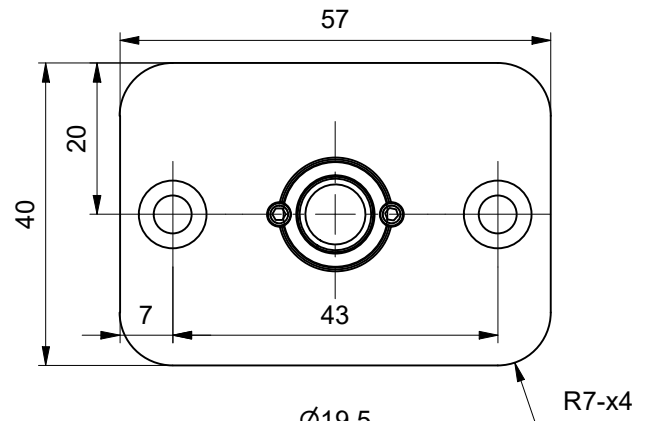
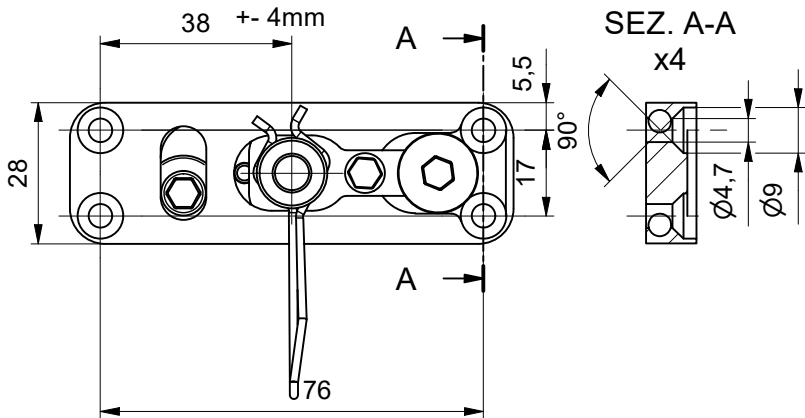
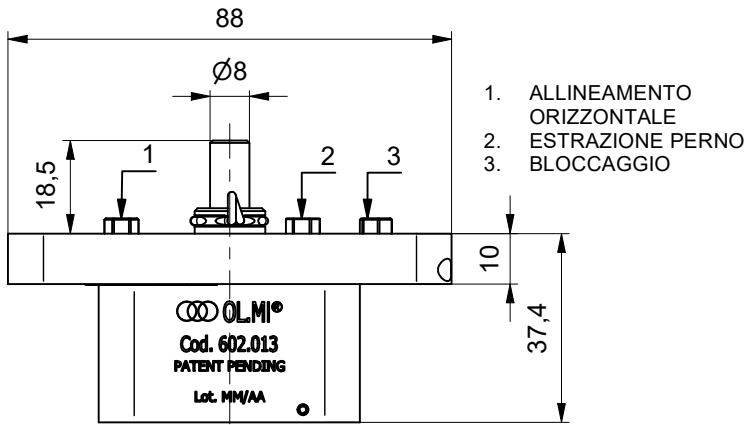
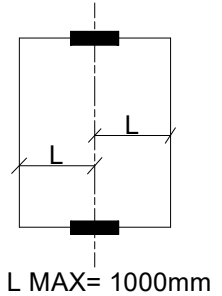

LAVORAZIONE
PORTA

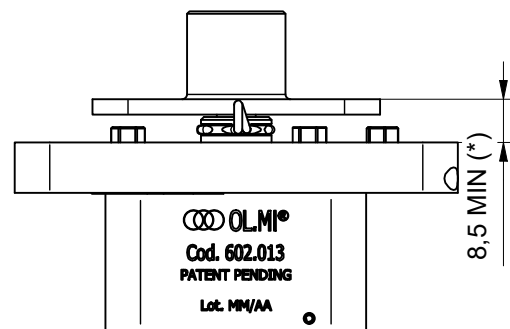
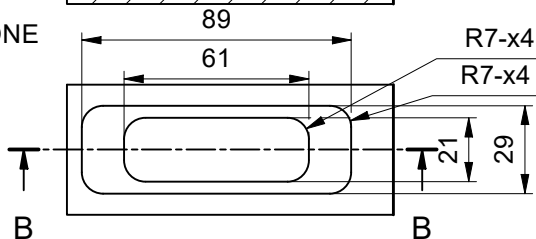

CODICE: 602.016-00

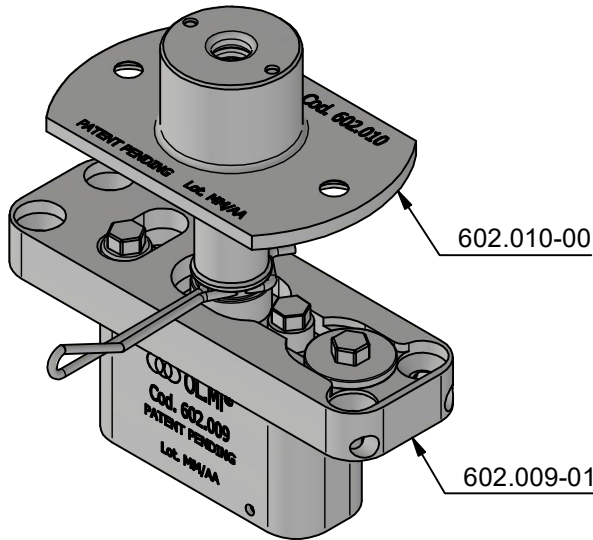

MASSA PORTA
120 kg - MAX

FINITURA NERA
OSSIDAZIONE
PROFONDA
50 micron

ALTEZZA
PORTA
min 1000 mm
MAX 3000 mm

INTERVALLO
UTILIZZO
min. -15 °C
MAX +40 °C

LARGHEZZA
PORTA
min 500 mm
MAX 1000 mm
* PORTA FINO A 2 METRI
IN BASE ALLA POSIZIONE
DELL'ASSE

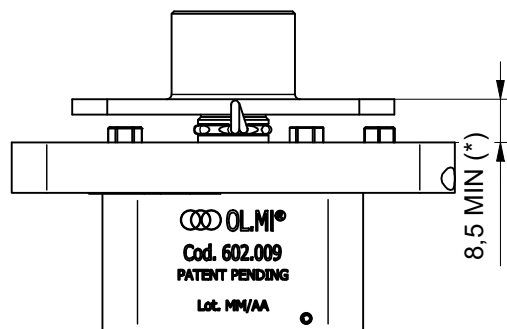
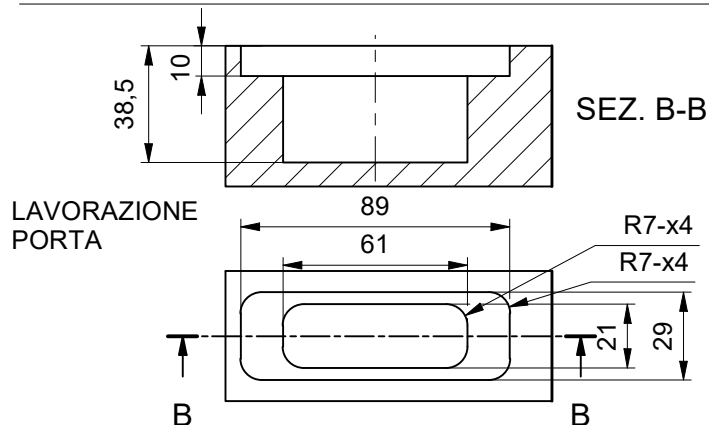
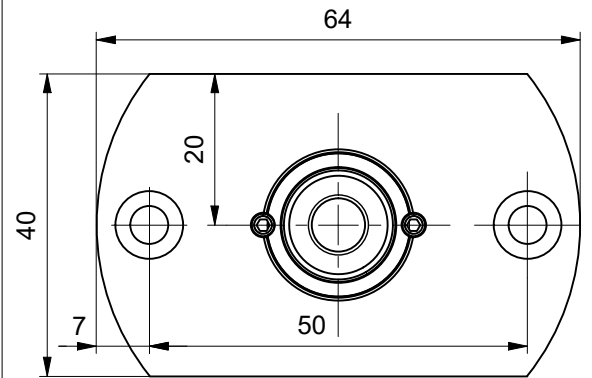
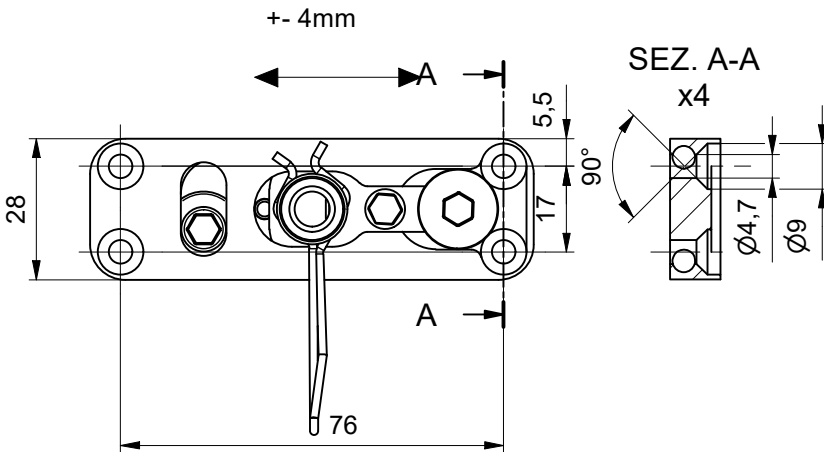
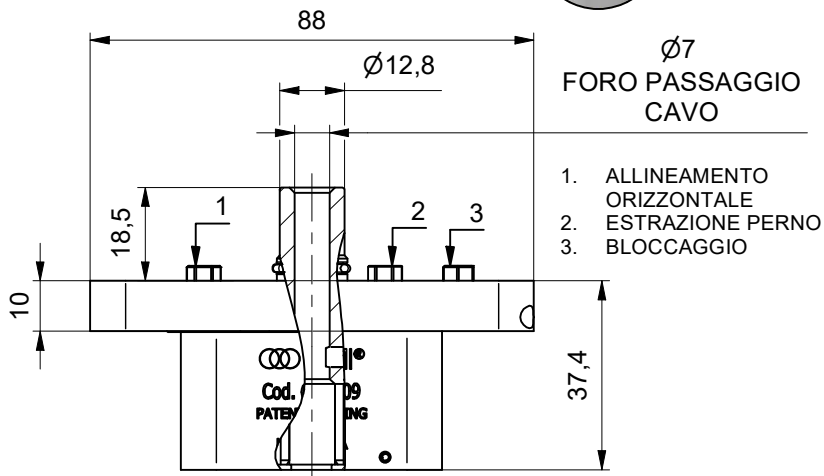
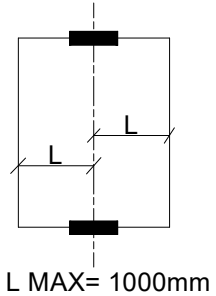

LE PRESTAZIONI RIPORTATE NELLA SCHEDA SONO RELATIVE AD INSTALLAZIONI EFFETTUATE A REGOLA D'ARTE